

NOTES:

1. MATERIAL: ALUMINUM (ANY 6--- OR 7--- SERIES)
2. ASSOCIATED CAD FILE: StageCornerBallPlate-R.STP
3. BREAK SHARP EDGES
4. QUANTITY: 1

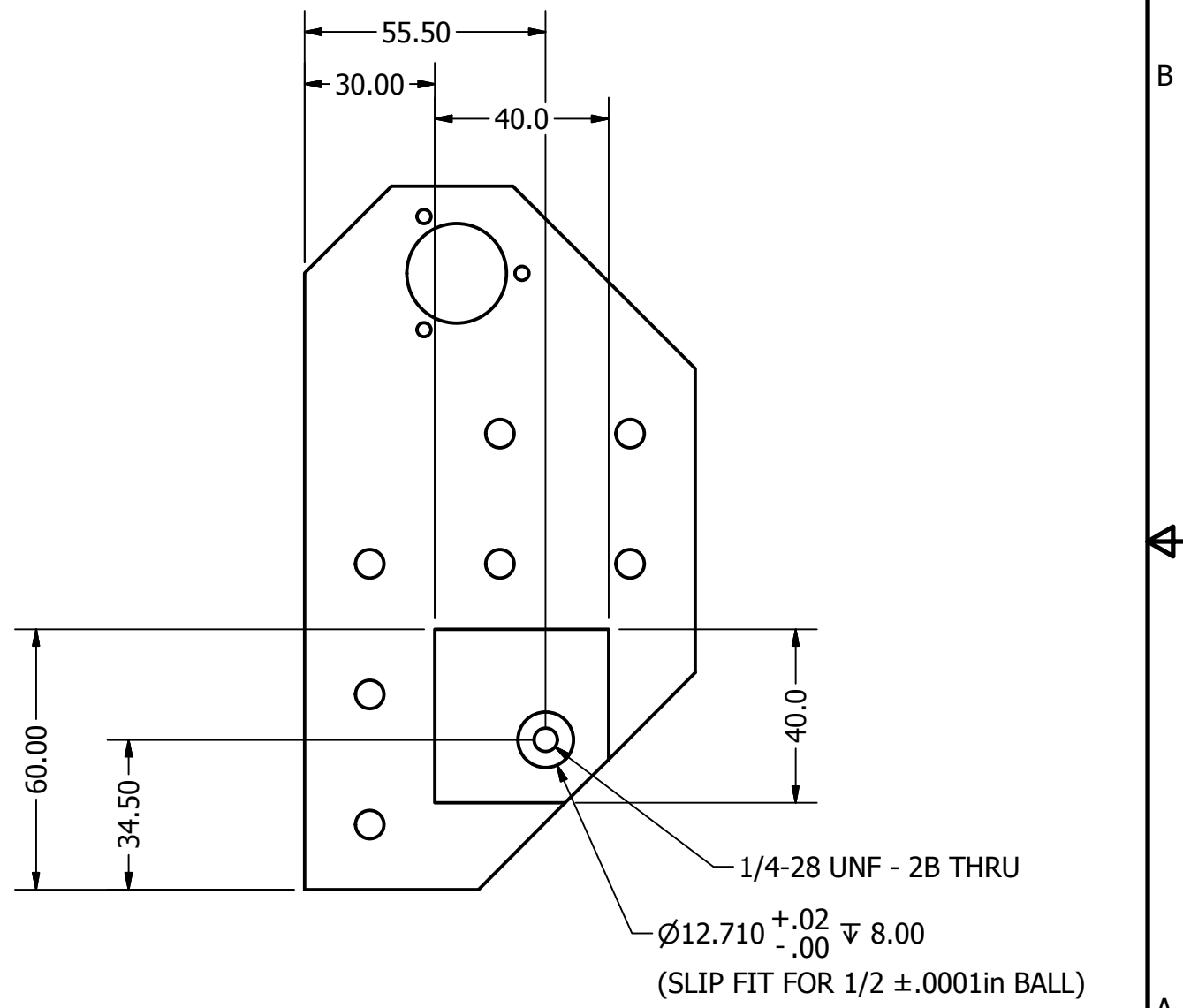
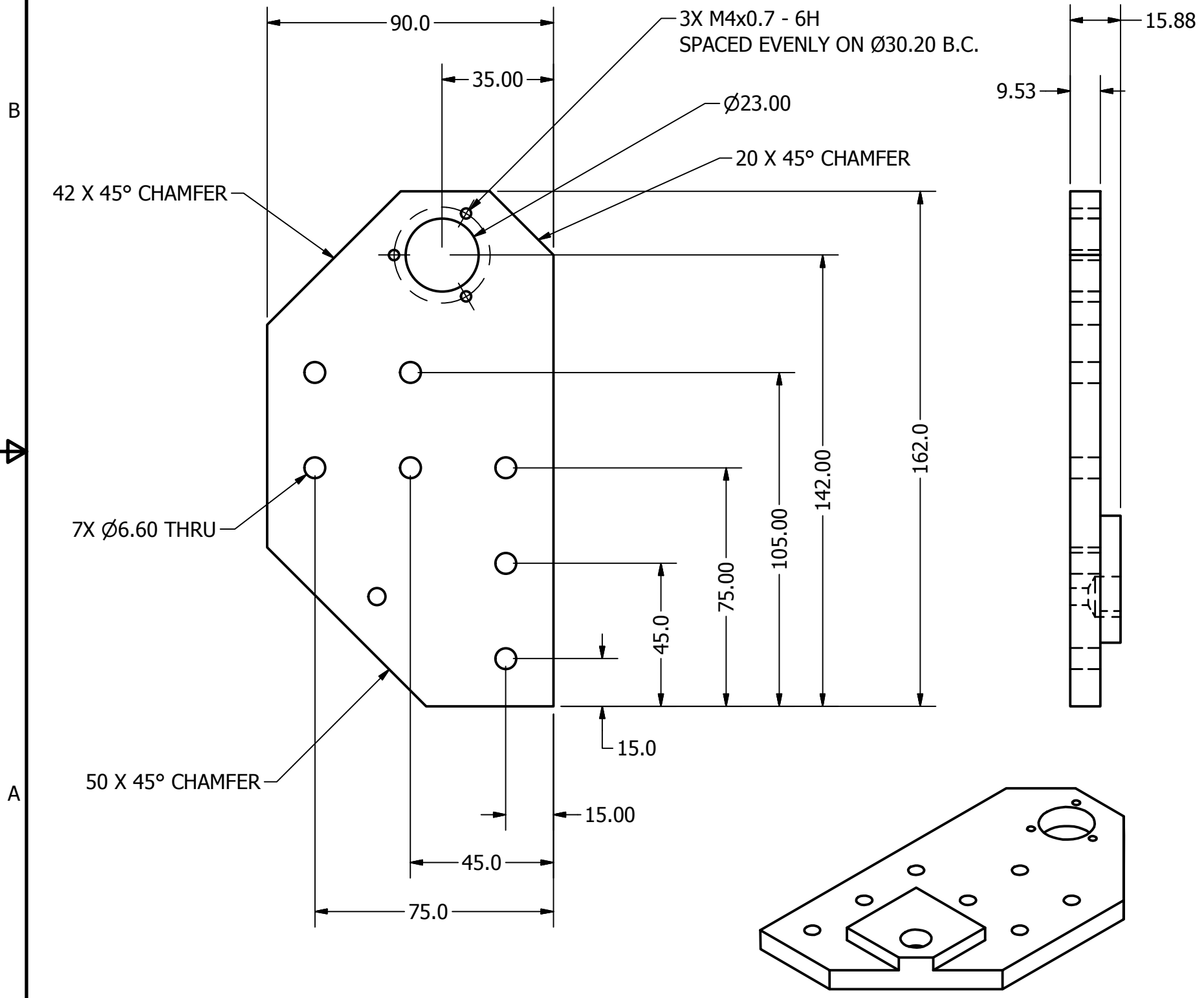

ENGINEER Justine Haupt		9/23/2018	
ALL UNITS IN mm DECIMAL TOLERANCES:			
X = ±.50			
X.X = ±.30			
X.XX = ±.16			
X.XXX = ±.08			
TITLE STAGE CORNER BALL PLATE,RH			
SIZE B	PROJECT	DWG NO LFPSCBPR	REV 0